

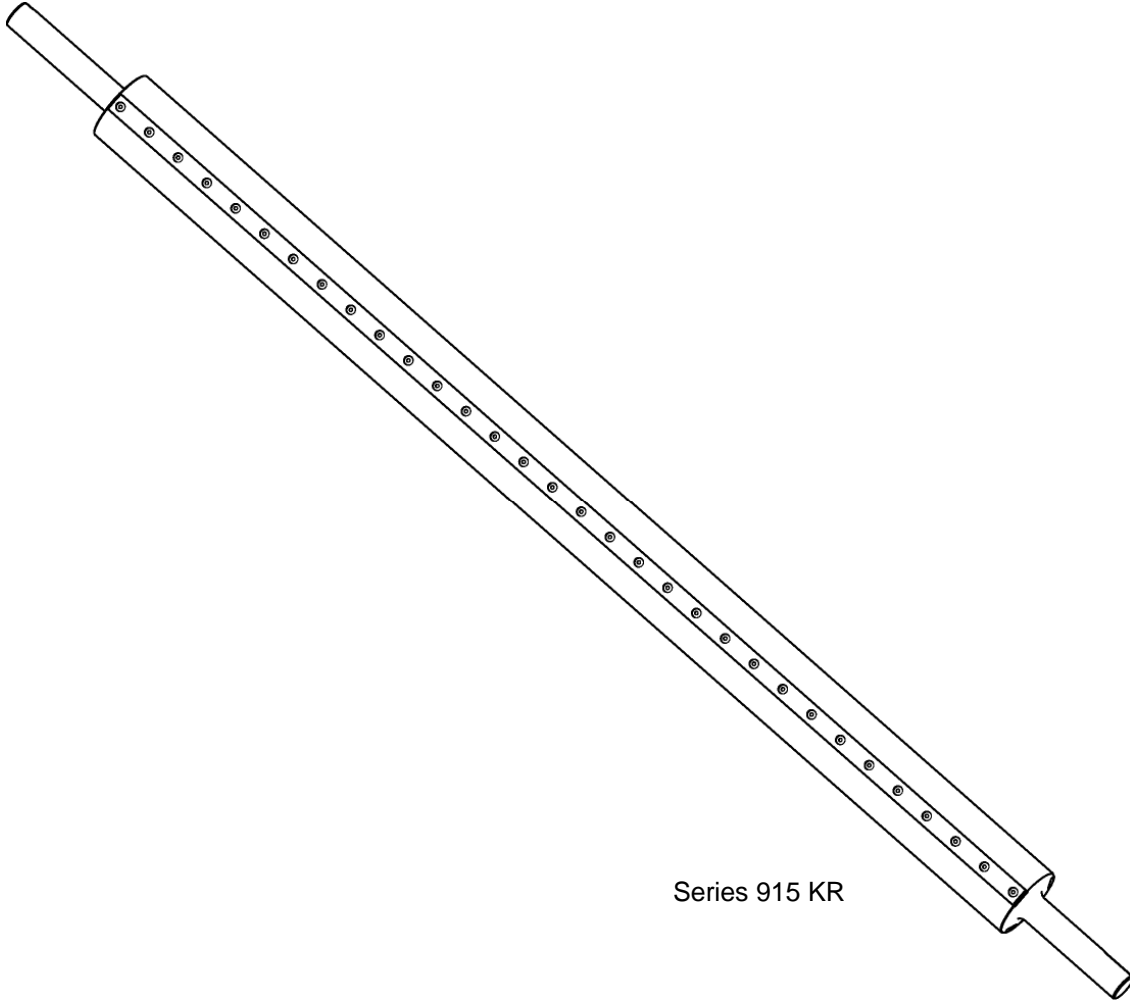

Series 905/910/915 Slitter Shaft

Installation, Operation and
Maintenance



Series 915 KR

Series 905 KT
Series 910 KS
Series 915 KR

IMPORTANT SAFETY INSTRUCTIONS

When using this Tidland product, basic safety precautions should always be followed to reduce the risk of personal injury. Your company's safety instructions and procedures should always be followed. When using this product with any other equipment or machinery, all safety requirements stipulated by that equipment or machinery manufacturer must be followed. Compliance with local, state, and federal safety requirements is your responsibility. No part of these or the following instructions should be construed as conflicting with or nullifying the instructions from other sources. Be familiar with the hazards and safety requirements in your work environment and always work safely.

1. Read and understand all instructions and shaft design application limits before operation.
2. Never use this product for a purpose or in a machine that it was not specifically designed for. See Product Safety Data Sheet (PSDS), if applicable.
3. Do not exceed the operation loads for this shaft as noted on its PSDS, Product Safety Data Sheet, if applicable.
4. Follow all warnings and instructions marked on the product and on the PSDS, if applicable.
5. Inspect the shaft for wear and/or other safety and functional deficiencies daily, before each use.
6. Wear safety glasses or proper eye protection when inflating or deflating or otherwise operating the air system, if applicable.
7. Do not remove or otherwise alter any setscrews or fastening devices prior to using this product.
8. Do not operate this product if any setscrews or fastening devices are missing.
9. Do not lift shaft manually if it is beyond your capacity. Loads over 1/3 your body weight may be prohibitive. Consult your company safety policy.
10. When lifting a shaft, use proper lifting techniques, keeping back straight and lifting with the legs.
11. Do not carry or lift this product over wet or slippery surfaces.
12. Use appropriate mechanical lifting devices, such as a hoist or shaft puller, for heavier shafts.
13. When performing maintenance or repair procedures, if applicable, do not pressurize the shaft if journal setscrews are loose or missing.
14. When performing maintenance procedures, if applicable, do not pressurize the shaft if the journal is missing.
15. All replacement parts used on this product should be made to original Tidland specifications.
16. All maintenance and repair procedures performed on this product should be done to Tidland specifications by qualified personnel.

TABLE OF CONTENTS

Important Safety Instructions	2
Caution	3
Tidland Customer Service	3
Recommended Tools	3
Maintenance Schedule	3
Shaft Nomenclature	4
Installation / operation	5
Shaft Notes	5
To Install Anvil Rings (Initial Setup)	5
Operation	5
To Reposition Anvil Rings	6
To Remove and Replace Anvil Rings	6
Maintenance	7
Daily	7
Centering Bars	7
Troubleshooting	8

CAUTION

- Tidland Slitter Shafts are designed to hold anvil rings in place during slitting operations.
- Knife blades and anvil rings are sharp! Avoid injury— always wear stainless steel protective gloves when handling knife blades and rings.
- Do not operate the shaft if any of the screws that secure the centering bars are missing or loose.



TIDLAND CUSTOMER SERVICE

1-800-426-1000

www.tidland.com

Visit the Tidland Repair and Return Center online to review our return policies or to submit an electronic Return Material Authorization Request.
www.tidland.com/repair

RECOMMENDED TOOLS

- Stainless Steel Protective Gloves (Part No. 132084)
- Hex drive wrench kit (Part No. 128363: L-Handle; 1.5, 2, 2.5, 3, 4, and 5mm)
(Part No. 132146: T-Handle; 2.5, 3, 4, 5, and 6mm)
- Wet/dry sandpaper – 600 grit (for removing small scratches and burrs from centering bars)

For more accessories to help with your slitting processes, visit www.tidland.com.

MAINTENANCE SCHEDULE

Daily

Throughout the operation shift, use clean compressed air to remove dust and debris from the shaft.

Wear eye protection when using tools or compressed air.



SHAFT NOMENCLATURE

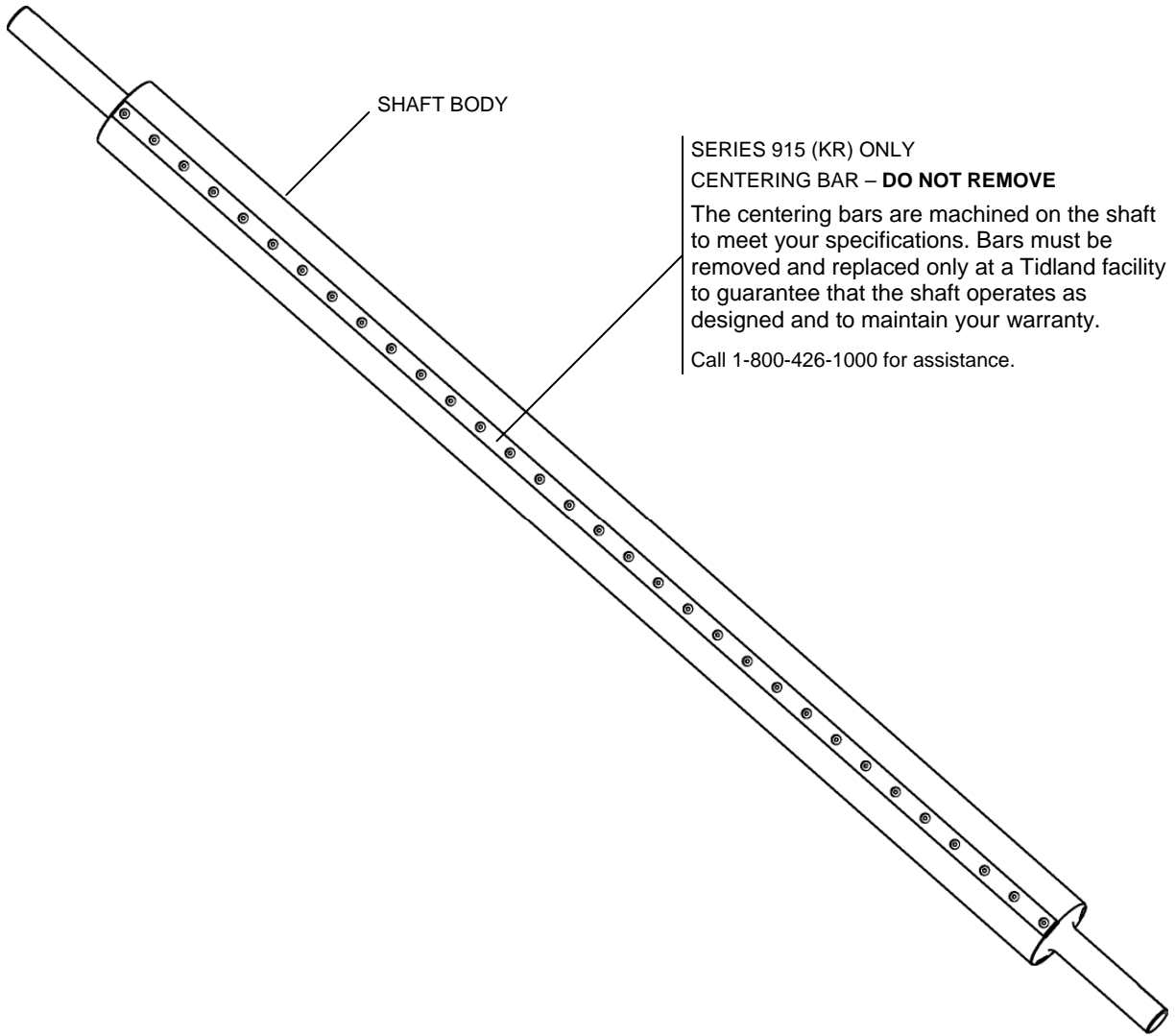

INSTALLATION / OPERATION

Shaft Notes

- Tidland Slitter Shafts are designed to hold anvil rings in place during slitting operations.
- Install shaft as required for your specific application: you may need to install anvil rings prior to shaft installation.
- Before each operation, inspect the body and centering bars (Series 915 KR only) for scratches that may prevent the anvil rings from moving freely along the shaft.
- Any large burrs or scratches on the shaft or centering bars must be removed.
 - Use 600 grit wet/dry sandpaper to smooth out the surface.
 - Heavily gouged or deformed centering bars should be replaced.
Call Tidland Customer Service 1-800-426-1000.

To Install Anvil Rings (Initial Setup)



HAND HAZARD

Keep hands away from knife blades at all times.
Knife blades can cause serious injury.

1. Complete your company lock-out/tag-out procedures to lock out system power.
2. Wear protective gloves when working with knife blades and anvil rings. Tidland recommends stainless steel gloves.
3. Make sure that the shaft is clean and dry and that all screws securing the centering bars (Series 915 KR only) are present and tight. **Do not exceed 45 in-lbs (5.1 Nm) torque. Overtightening will result in deformed centering bars.**
4. Install the anvil rings (and spacers, if applicable), making sure that sharpened edges are toward the slitting sides of the knife blades.
Note: Standard Tidland anvil rings are reversible with dual slitting edges: otherwise, install the anvil ring with the sharpened edge toward the slitting side of the knife blade.
5. Lock the anvil rings in place by tightening the three brass-tipped setscrews onto the steel body. **Note:** The Series 905/910 (KT and KS) shafts are designed with a keyway along the length of the shaft. Setscrews must be aligned in the keyway before tightening.
6. Reverse your company lock-out/tag-out procedures to restore system power.

NOTICE

Do not tighten the setscrews onto the centering bars. This will deform the centering bars and may prevent free movement of the anvil rings.

OPERATION

See your Tidland Knifeholder Manual for detailed knifeholder setup and operation.

To Reposition Anvil Rings

1. Stop shaft rotation.
2. Complete your company lock-out/tag-out procedures to lock out system power.
3. Ensure that the shaft is clean and dry.
4. Loosen the setscrews that secure the anvil rings (and spacers, if applicable).
5. Move the anvil rings (and spacers, if applicable) to the desired location.
6. See your knifeholder manual for repositioning and setup at new anvil ring locations.
7. Lock the anvil rings in place by tightening the three brass-tipped setscrews onto the steel body. **Note:** For Series 905/910 (KT and KS) shafts, align the setscrews in the keyway before tightening.
8. Reverse your company lock-out/tag-out procedures to restore system power.
9. Resume shaft rotation.

To Remove and Replace Anvil Rings

Remove Anvil Rings

1. Stop shaft rotation.
2. Complete your company lock-out procedures to lock-out system power.
3. Loosen the setscrews in the anvil rings.
4. Slide the anvil rings along the slitter shaft toward the removable bearing.
5. To help ensure safety and avoid damage to the system, provide alternative support for the slitter shaft before removing the bearing.
6. When slitter shaft is properly supported, remove bearing.
7. Remove anvil rings (and spacers, if applicable) by sliding them off the shaft through the opening in the side frame.
8. Leave the shaft in a supported position.

Reinstall Anvil Rings

1. Slide the anvil rings (and spacers, if applicable) onto the shaft, making sure that sharpened edges are toward the slitting sides of the knife blades.
Note: Standard Tidland anvil rings are reversible with dual slitting edges: otherwise, install the anvil ring with the sharpened edge toward the slitting side of the knife blade.
2. Reinstall the removable bearing and remove the alternate shaft support.
3. Move the anvil rings (and spacers, if applicable) to the desired location.
4. See your knifeholder manual for repositioning and setup at new anvil ring locations.
5. Lock the anvil rings in place by tightening the three brass-tipped setscrews onto the steel body. **Note:** For Series 905/910 (KT and KS) shafts, align the setscrews in the keyway before tightening.
6. Reverse your company lock-out procedures to unlock the system power.
7. Resume slitting operation.

Wear eye protection when using tools or compressed air.



Daily

- Throughout the operation shift, use clean compressed air to remove dust and debris from the shaft and the centering bars.
- Use a mild solvent, such as rubbing alcohol, to clean residue from the shaft. Dry shaft thoroughly.
- Before each operation, inspect centering bars (Series 915 KR only) and the shaft body for scratches that may prevent the anvil rings from moving freely along the shaft.
- Any large burrs or scratches on the shaft or centering bars must be removed.
 - Use 600 grit wet/dry sandpaper to smooth out the surface.
 - Heavily gouged or deformed centering bars should be replaced. Call Tidland Customer Service 1-800-426-1000.

Centering Bars

(Series 915 KR shafts)

- The centering bars, made from Acetron® GP Acetal (a general purpose copolymer), help ensure accurate positioning for your anvil rings.
- Keep the bars and the shaft free from grit and scratches so that the anvil rings slide smoothly along the length of the shaft.
- Small burrs, scratches and deformities can be smoothed out using 600 grit wet/dry sandpaper.
- Large gouges or deformities may require replacement of the centering bars. Call Tidland Customer Service for assistance. 1-800-426-1000.

Do not remove the centering bars. The centering bars are machined on the shaft to meet your specifications. Bars must be removed and replaced only at a Tidland facility to guarantee that the shaft operates as designed and to maintain your warranty.

TROUBLESHOOTING

Problem	Possible Cause	Recommended Solution
Anvil rings do not slide on the shaft	Anvil ring setscrews are still tightened.	Loosen anvil ring setscrews.
	Series 905/910: Shaft body may be badly scratched.	Scratches and burrs along the shaft body can be removed by using 600 grit wet/dry sandpaper. Smooth the surface until the anvil rings move freely on the shaft
	Series 915KR: Centering bar hardware is loose.	Ensure that all of the screws are present and tight. Do not exceed 45 in-lbs (5.1 Nm) torque.
	Series 915KR: Centering bars are badly scratched or deformed.	Scratches and burrs along the centering bars can be removed by using 600 grit wet/dry sandpaper. Smooth the surface until the anvil rings move freely on the centering bars. Badly deformed centering bars should be replaced. Call Tidland Customer Service 1-800-426-1000.

All rights reserved. No part of this publication may be reproduced, transmitted, transcribed, stored in a retrieval system, or translated into any language in any form by any means without the written permission of Tidland Corporation.



Tidland Corporation
 2305 SE 8th Avenue
 Camas, WA 98607 USA
 Phone: 1-800-426-1000
 1-360-834-2345
 Fax: 1-360-834-5865
 E-mail: tidland@tidland.com
 Web: www.tidland.com

Maxcess Europe
 Fifestrasse 1, D-65779
 Kelkheim/Ts., Germany
 Phone: (49) 6195-7002-433
 Fax: (49) 6195-7002-933
 E-mail: info@maxcess.eu

Maxcess Asia
 300 Orchard Road No. 15-05
 Orchard Towers
 Singapore 238875
 Phone: (65) 9820-3883
 Fax: (65) 6235-4818
 E-mail: asia@maxcessintl.com